

Capacity	0.5 - 6.6 MW
Fuel oil	Heavy Fuel Oil up to 700 cSt/50 °C Marine Diesel Oil Marine Gas Oil
Turn down ratio	1:3 for burners up to 2 MW 1:4 for burners from 2 - 4 MW 1:5 for burners > 4 MW

Design Features

The SAACKE SKVJ-M monoblock rotary cup burner is designed for smaller sized marine boilers. It is suitable for

- side fired furnace boilers and
- classic two- or three-pass smoke tube boilers.

The SKVJ-M burner is designed as a very compact system with focus on easy installation, operation and maintenance.

The unique design of the SKVJ-M burner with integrated modulating heater combines all advantages of economic, operationally reliable and environmentally friendly combustion:

- Highest combustion quality even at lowest grade fuel oils
- Insensitivity against fuels of different quality and contamination

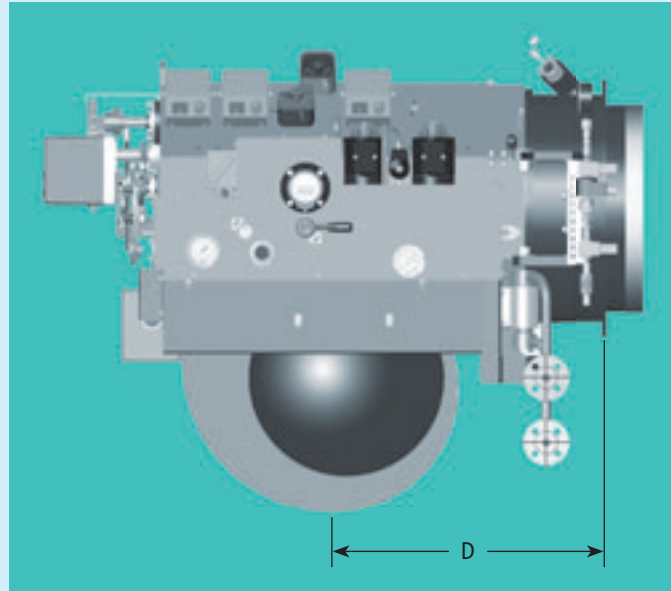
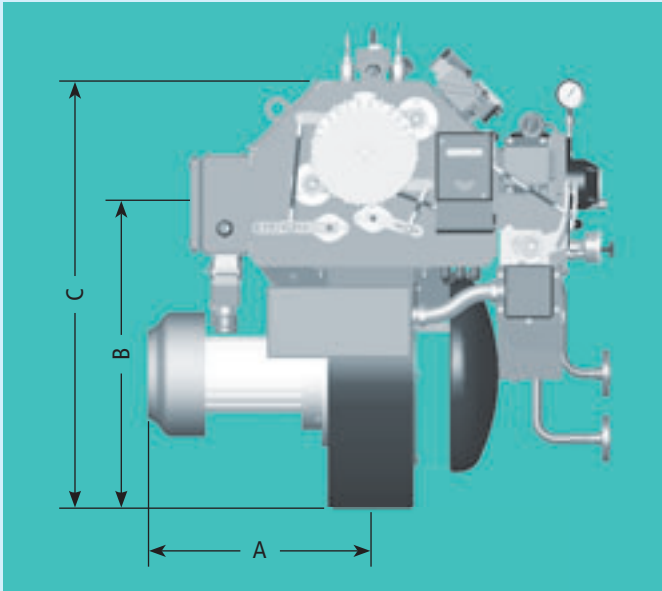

Burner type	max. capacity MW	A mm	B mm	C mm	D mm	Burner weight kg
SKVJ-M 10	1.2	468	632	890	541	325
SKVJ-M 14	1.6	468	632	890	541	330
SKVJ-M 18	2.1	468	632	890	541	340
SKVJ-M 24	2.7	572	714	972	566	360

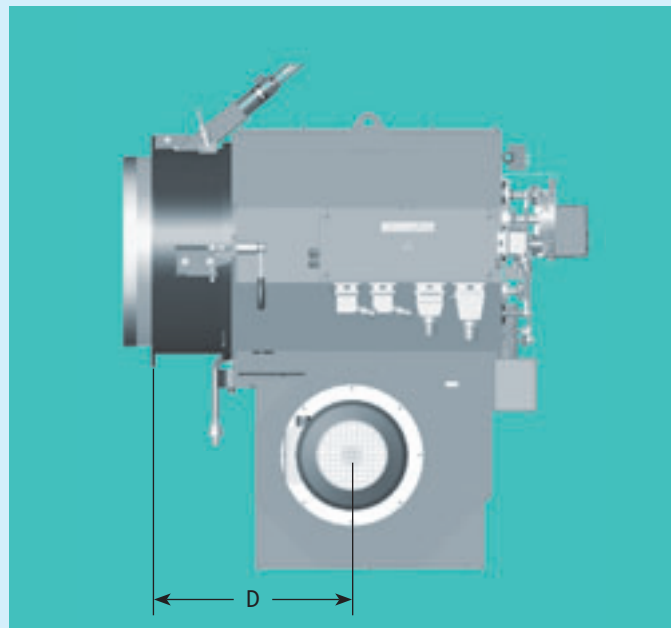
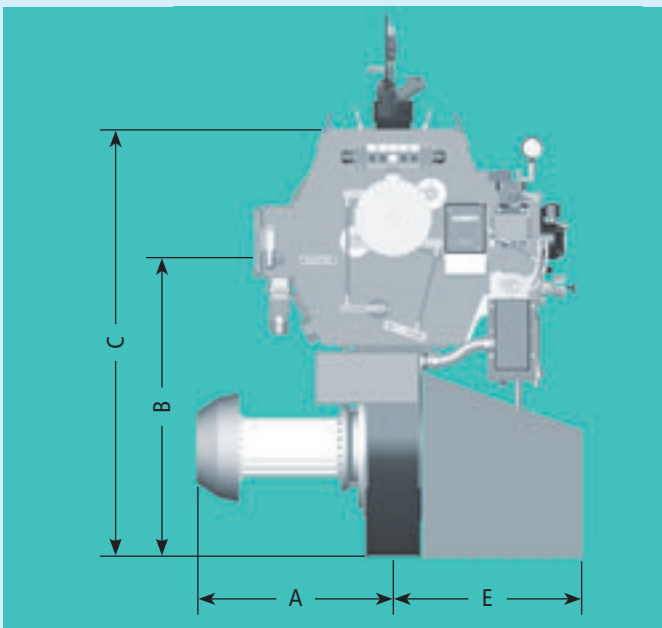

Burner type	max. capacity MW	A mm	B mm	C mm	D mm	E mm	Burner weight kg
SKVJ-M 28	3.3	561	892	1235	562	543	675
SKVJ-M 36	4.1	561	892	1235	562	543	690
SKVJ-M 46	5.2	561	936	1235	562	558	700
SKVJ-M 58	6.6	568	936	1280	562	558	720